



## TeleCtrl Industrial Remote Control

Address : Opposite Zongyang No. 3 Middle School, Tongling City, Anhui Province, China

TEL : (8621)-6997-9981

Email : te@telectrl.com



## Industrial Remote Control

### User Manual



Applicable Models Covered by This Manual: F24 Series, F24 + Series, F24 Pro Series

Thank you for choosing TeleCtrl industrial remote controls. Before installing and using the remote control, operators should read the manual carefully and ensure they fully understand the contents. Keep this manual properly for easy reference.

# Introduction

Thank you for choosing TeleCtrl industrial remote controls. TeleCtrl has several brands under its umbrella, including TELECTRL, TELECRANE, KNOVDEC, EUTOPIA, APOLLOCRANE, TOK, SAGACRANE, and SAGARADIO. We produce and operate over 20 types and more than 200 models of industrial remote control products. Our products are widely used in cranes and other industrial fields, and have a good reputation in the industry. TeleCtrl can provide you with the most suitable products and solutions according to your requirements, and offer various customization services.

This manual applies to most models of TeleCtrl remote controls, providing necessary information on product installation, operation, and maintenance. Please read this manual carefully before using the product.

## Table of Contents:

I. Introduction	01
II. Safety Instructions	02
III. Product Overview	03
IV. Transmitter Power Selection	06
V. Installation and Usage	07
VI. Product Maintenance	11
VII. Common Issues and Solutions	13
VIII. Packaging and Transportation	14
IX. Warranty Terms and Conditions	15
X. Legal Disclaimer and Usage Restrictions	15
XI. Inspection Certificate	16
XII. User Feedback and Support	16

# Safety Instructions

1. Our company cannot fully understand local laws and regulations. Buyers should ensure that the purchased product parameters comply with local laws and regulations, such as radio frequency signal frequency and explosion-proof requirements.
2. Before installing and using the remote control, operators should read the manual carefully and ensure they fully understand the contents. Keep this manual properly for easy reference.
3. Operators should strictly follow the instructions in this manual for installation and use of the remote control. Improper operation may lead to serious safety accidents.
4. The remote control must be installed and used by professionally trained personnel. Ensure that all users are authorized. Do not allow individuals who are slow to react, emotionally unstable, or have unclear consciousness to use the remote control.
5. Unauthorized modification or disassembly of the remote control may result in damage and void all warranties.
6. We cannot provide professional advice or answers for all special and professional applications. If the remote control is used in highly dangerous situations, such as under high-voltage power lines, users must take effective tests to evaluate and avoid safety accidents. Our company does not assume legal responsibility for any losses or injuries caused by this.
7. The manufacturer may modify or update the product and the contents of this manual from time to time. The modified functions or contents will not be notified to customers separately. Please be informed.

## Product Overview

TeleCtrl industrial remote control products use top global brand chips and components, employing LoRa low-power remote communication technology, as well as advanced technologies such as narrowband communication and frequency hopping to reduce or avoid interference. This ensures that the product signals are stable, economical, and durable.

### Product Structure and Description:

#### 1. Handheld Operation Part

Commonly referred to as: transmitter, handle;

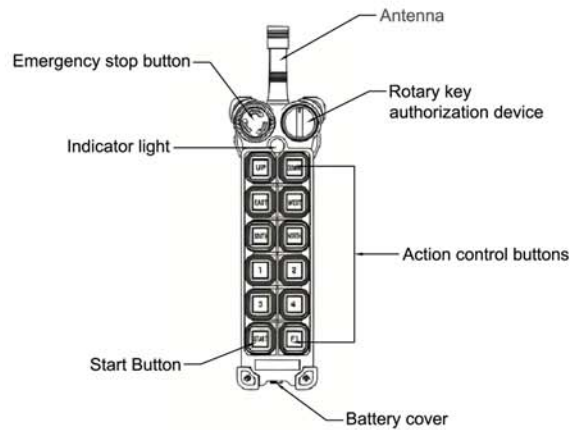

#### 2. Control Cabinet Installation Unit:

Commonly known as: Receiver, Receiving device.

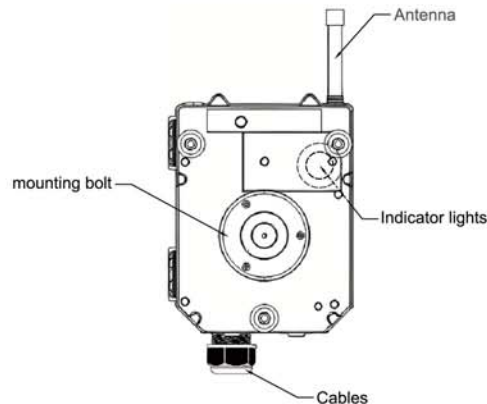

## Product Overview

### Product Dimensions and Specifications:

#### 1. Transmitter Specifications Table

Model	Antenna Style	Magnetic EMS Button	Rotary Key	Dimension	Weight
F24-6D	External	●	●	186x61x51mm	280g
F24-6S	External	●	●	186x61x51mm	280g
F24-6S Mini	External	●	●	156x61x51mm	255g
F24-8D	External	●	●	186x61x51mm	280g
F24-8S	External	●	●	186x61x51mm	280g
F24-10D	External	●	●	186x61x51mm	280g
F24-10S	External	●	●	186x61x51mm	280g
F24-12D	External	●	●	186x61x51mm	280g
F24-12S	External	●	●	186x61x51mm	280g
F24-14D	External	●	●	239x61x51mm	360g
F24-14S	External	●	●	239x61x51mm	360g
F24-60	Internal	●	●	210x152x128mm	980g

Enclosure: Glass Fibre PA, Transmitter Power: 2AAbatteries; F24 + Series: 4AAbatteries; F24 Pro Series: lithium batteries.

#### 2. Receiver Specifications Table

Model	Adjustable Voltage	Fixed Voltage	Dimension	Weight
F24-6D	●		210x162x107mm	1220g
F24-6S	●		210x162x107mm	1220g
F24-6S Mini	●		210x162x107mm	1220g
F24-8D	●		210x162x107mm	1220g
F24-8S	●		210x162x107mm	1220g
F24-10D	●		210x162x107mm	1220g
F24-10S	●		210x162x107mm	1220g
F24-12D	●		210x162x107mm	1220g
F24-12S	●		210x162x107mm	1220g
F24-14D	●		210x162x107mm	1220g
F24-14S	●		210x162x107mm	1220g
F24-60	●		320x253x107mm	2020g

Enclosure: Glass Fibre PA.

#### General Product Parameters:

- Radio frequency band: VHF: 310~331MHZ, UHF: 425~446MHZ (the working frequency band will be adjusted according to the requirements of different countries).
- Operating environment conditions: (1). Ambient temperature is usually -35°C ~ +80°C; (2). Relative humidity not exceeding 95%; (3). Atmospheric pressure: 86KPa~106KPa; (4). When used in areas with acidic or alkaline corrosive gases, dust, or strong electromagnetic field interference, corresponding countermeasures should be taken.
- (1). Safety code: 32 bits (4.3 billion); (2). Emission Power <10 dbm; (3). Effective control distance, standard configuration 100M (open and unobstructed). (4). Protection level complies with IP65 regulations. For special requirements on control distance and protection level, please customize.

## Product Overview

**Wiring Diagram** ( See the receiver nameplate for wiring diagrams of additional models ).

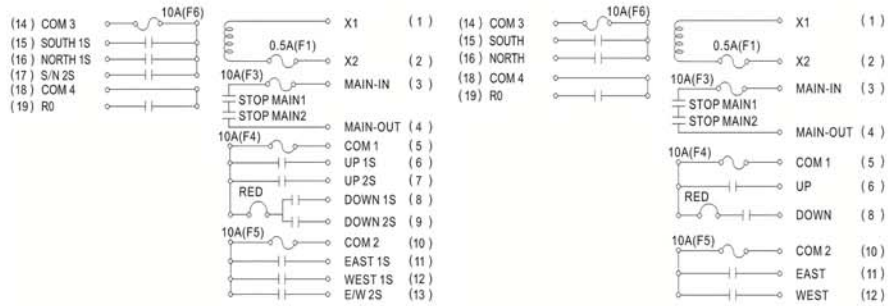

F24-6D

F24-6S

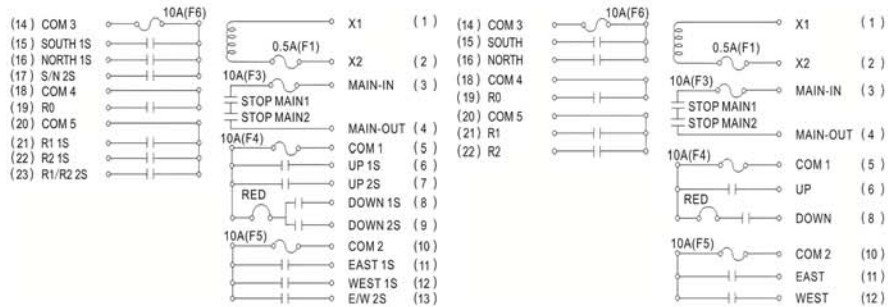

F24-8D

F24-8S

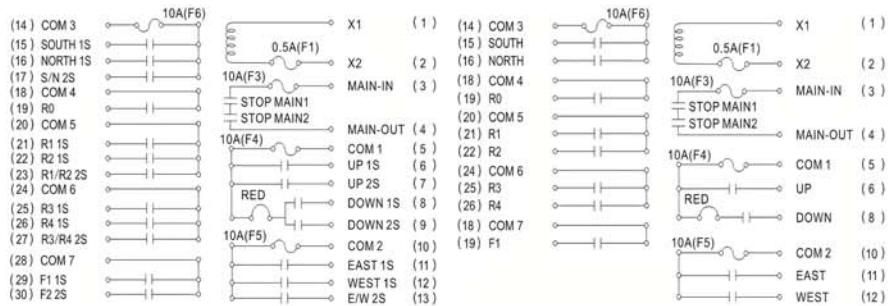

F24-12D

F24-12S

## Transmitter Power Selection

- Standard models of the transmitter are equipped with two AA batteries (optional for four batteries). Products marked with "+" in the F24 series use four AA batteries.
- Batteries can use ordinary alkaline AA batteries or rechargeable batteries, but do not mix the two types of batteries or mix old and new batteries.
- Products marked with "Pro" in the F24 series use special lithium batteries. Users must use the supporting lithium batteries and chargers provided by our company to ensure long-term stable use of the machine.

### Charger and Rechargeable Battery (Applicable only to charging models)

#### Regarding Rechargeable Batteries:

- Properly store batteries to avoid short circuits. If not used for a long time, periodically check and maintain the lithium battery, and charge and discharge it every two months to maintain good battery performance.
- The standard capacity of lithium batteries is 2000mAh, and the charging voltage is 4.2V. The continuous use time is about 150 hours (the time varies with power consumption settings).
- When charging a new battery for the first time, continue charging for 2 hours after it is fully charged to ensure the best use effect.
- Do not use a charger with mismatched parameters to charge the battery, and the charging voltage should not exceed the indicated voltage.
- Since charging generates heat, ensure that the charger is in a well-ventilated environment to charge the battery to prevent fire.
- If equipped with multiple rechargeable batteries, alternate use to ensure they are frequently charged and discharged to avoid damage. If not used for a long time, properly store and maintain them.
- If the battery exhibits abnormal charging and discharging or has a short usage time, it may be due to improper use conditions or a malfunction. Please consult the dealer for handling.
- If the battery is swollen or bulging, it indicates that the battery is completely damaged and should be replaced immediately to avoid accidents.

#### Regarding Chargers:

- The polymer lithium battery used in our products requires a special charger provided by our company. The charging time is generally not less than 5 hours.
- There are two types of chargers, AC110V/220V and DC5V. The default configuration is a 5V USB charger. If you need an AC110/220V charger, it must be purchased separately.

#### Charger Working Status Indicator Light:

Without battery	The power indicator light is on	The charging indicator light is off
Charging	The power indicator light is on	The charging indicator light is flashing
Fully charged	The power indicator light is on	The charging indicator light is on

### Transmitter Installation and Usage

1. Install transmitter batteries: Insert two AA 1.5V alkaline batteries or the provided rechargeable batteries into the battery compartment in the correct direction;
2. Pull up the emergency stop switch, insert the rotary key, and turn it clockwise to the "ON" position. If it is a magnetic switch type, attach the magnet;
3. Press the "START" button. At this time, the working indicator light will flash green slowly (Note: the transmitter is not turned on according to the operating steps, the indicator light will flash red quickly. If the switch is in the "OFF" position, some models' indicator lights will not turn on).
4. Perform an operation test according to the function settings of the buttons on the transmitter.

#### After the operation is completed, handle it in the following order:

1. Press the STOP button (if any) and press the EMS emergency stop switch;
2. Turn the rotary key counterclockwise to the "OFF" position; Note: Turning to the "OFF" position not only turns off the action output of the transmitter but also turns off the standby state of the transmitter, reducing power consumption.
3. Remove the key and store it properly. For magnetic switch machines, remove the magnetic switch;
4. If not used for a long time, remove the batteries from the battery compartment.

Note: The transmitter has a power monitoring function and displays the power status through the power indicator light.

- Green — indicates sufficient power, and the transmitter can operate normally.
- Yellow — indicates the battery power is about to run out. If the indicator light shows yellow, suspend work (for example, lower the hanging object to the ground) and replace the battery.
- Red — indicates insufficient power. At this time, the transmitter will automatically send an emergency stop signal to turn off the receiver. Therefore, operators should avoid low power situations to ensure safe use of the machine.

For models without a separate power indicator light, if the red light of the shutdown indicator lights up while the green light is flashing normally during operation, the battery needs to be replaced immediately.

#### Receiver Installation Preparation:

- ①. Phillips screwdriver; ②. Hex wrench 13mm; ③. Electric drill (drill bit  $\Phi 8.5\sim 9\text{mm}$ ); ④. Wire stripper; ⑤. Connecting cable; ⑥. Insulating tape; ⑦. Safety protective equipment (gloves and safety glasses, etc.); ⑧. Receiver.

### Receiver Input Power Voltage Selection (Applicable to regular machines)

Receivers based on the CC430F5137/5 platform have two power supply modes:

1. Fixed voltage transformer Before use, confirm the power supply voltage of the receiver and order the required voltage specifications from the dealer.
2. Adjustable voltage transformer The receiver has a built-in adjustable transformer that provides three power supply voltage options. Select the appropriate voltage according to the actual needs. When selecting, refer to the voltage value marked by the yellow label next to the transformer interface.

#### Method for Changing Input Power Voltage:

1. Turn off the receiver power.
2. Remove the power connector from the default position (as shown in the figure below).
3. Select the correct voltage interface as needed and reinsert it.



Note: TeleCtrl industrial remote control provides four transformer specifications for selection. Users can customize products with different specifications of transformers according to different needs.

Transformer specifications:

- ①. 36V/220V/380V; ②. 48V/220V/380V; ③. 110V/220V/380V; ④. 48V/110V/380V

### Installation Steps:

1. Check the equipment accessories to ensure that the receiver's allowable voltage matches the equipment voltage. Turn off the equipment power;
2. Follow the specific model wiring diagram in the manual to correctly connect and secure the cables. After the connection is complete, wrap any unused cable connectors with insulating tape.
3. Choose a suitable location to drill holes and fix the receiver. When determining the installation location, consider the following:
  - Choose a location without metal obstructions and visible to the transmitter;
  - If installed in a metal cabinet, use an external suction cup antenna;
  - Keep away from heat sources, inverters, motors, and other high-power equipment to avoid interference. Shielding measures can be taken if necessary;
  - Choose a safe location to avoid adverse weather, corrosive substances, and mechanical vibrations or impacts.
4. Turn on the power, check the connection, and test, and check the emergency stop function and other safety settings.

### Explanation of Power Indicator Lights:

Some models of remote control receivers are equipped with indicator lights. The functions of the indicator lights vary depending on the model.

1. Indicator lights with a diameter of about 37.5mm are only power indicator lights. When the receiver power supply is normal, the receiver indicator light is always on. No other functions are indicated. If the indicator light is off, check whether the power supply is normal.
2. Indicator lights with a diameter of about 80mm are functional indicator lights. Below are the functional indicator light status indications corresponding to the functions:

Indicator Light Status Description	● ON — OFF ■ Steady ON
In Standby Mode	● — ● — ● — ●
Power On but No Relay Engaged	■
In Operation Mode	● — ● — ● — ● — ●
In Fault Mode	● — ● — ● — ● — ● — ● — ● — ● — ●

Note: "In Operation Mode" indicates that, in addition to the main stop relay being engaged, other relays are also engaged, including those set to momentary contact mode.

### CEmergency Handling:

Operators must be familiar with the following emergency handling steps before use.

1. Press the EMS emergency stop button.
2. Turn the rotary key to the "OFF" position and remove the key. For magnetic switch models, remove the magnetic switch.
3. Turn off the main power supply of the crane and stop all operations.
4. Contact the dealer to identify and resolve the issue.

### Precautions:

- The equipment controlled by the remote control must be equipped with necessary safety facilities, such as main power relays, limit switches, emergency stop switches, and other necessary safety devices for crane control. Do not use our company's products if safety measures are not in place;
- Before operating the equipment, confirm that the environment is safe, with good visibility and no potential hazards. Non-staff members are not allowed in the working range of the controlled equipment.
- Before each operation, the emergency stop function of the remote control equipment must be checked. Specifically, turn on the remote control normally, operate the equipment to move, and immediately press the emergency stop button to observe whether the equipment immediately enters the emergency stop state without any extra actions. If pressing the emergency stop button does not bring the equipment into the emergency stop state, immediately stop using the remote control equipment and contact the after-sales service department of the dealer for handling;
- When the device function is damaged or an emergency occurs, immediately press the emergency stop button on the transmitter;
- When exceeding the remote communication distance or experiencing severe signal interference, operation delays or lags may occur. In such cases, stop operating the machine. CC430F5137/5 series products have frequency hopping functions. After interference, simply turn off the machine and restart it, and the machine will work on a different channel;
- If the controlled equipment retains both remote and wired control functions simultaneously, there must be an interlock device to ensure they are not used simultaneously.
- When performing welding operations on the controlled equipment connected to the receiver, or if the connection will exceed the rated voltage and current allowed by the receiver, disconnect the connection between the receiver and the equipment and isolate it to avoid equipment damage or safety accidents;
- Each remote control is set with a unique safety code at the factory. However, during actual installation and use, avoid using devices with the same channel within a linear distance of 200 meters as much as possible.
- To ensure long-term stable use of the remote control, reduce or avoid operating in the rain or environments with corrosive gases (except for special custom models, the protection level of the remote control is IP65).
- When the transmitter is not in use, it should be safely placed and stored to avoid accidental button presses.

## Product Maintenance

- The transmitter should be regularly checked and maintained, including checking the emergency stop function before each use.
- The transmitter should be regularly checked for damage or wear on switches and other parts. If found, they should be replaced immediately.
- Keep the transmitter clean and protect its nameplate and buttons from damage, ensuring clear and legible markings.
- The rubber cover of the transmitter provides waterproof, dustproof, and protective functions. Replace it if damaged.
- If the transmitter housing is damaged, cracked, or leaks water, replace it immediately.
- If the protective shoulder strap of the transmitter's fixed waist belt is damaged, repair or replace it immediately.
- If the receiver's mounting feet are damaged or deformed, repair or replace them promptly.
- If the receiver is damaged, deformed, or cracked, and its waterproof and dustproof functions are compromised, repair or replace it immediately.

### Transmitter and Receiver Pairing:

When one of the components of the remote control (either the receiver or transmitter) fails and needs replacement, pairing must be redone. Different models have different pairing methods, commonly using a copy machine to copy electronic cards (F21/F23/F24 series) and wireless pairing (supported by some models).

Note that new transmitter operations are professional operations. Improper operations can render the machine unusable. Please follow the company's social media accounts or contact the dealer for operation video guidance.

### Software Modification Functions:

The functions of the remote control buttons, button operating modes, and automatic shutdown times can be modified and set through computer software connected to the copy machine and electronic cards. However, software function modification is a professional operation. Improper operations can render the machine unusable. Please follow the company's social media accounts or contact the dealer for operation video guidance.

TeleCtrl provides free operating software but cannot offer one-on-one software usage training for every end customer. For more questions during operation, please contact your dealer.

## Product Maintenance

### Changing Remote Control Channels by Replacing Quartz Crystals:

Some products can change communication channels by replacing quartz crystals. If you want to change channels, especially when channels overlap or are interfered with, replace the quartz crystals in both the transmitter and receiver with the desired channel. Changing the channel does not require modifying the program in the chip.

The method for replacing quartz crystals is as follows:

1. Use a flat-blade screwdriver to pry up and remove the quartz crystal to be replaced.
2. Use needle-nose pliers to straighten the pins of the new quartz crystal and insert them vertically into the corresponding holes on the circuit board.
3. Press the quartz crystal into the protective seat to secure it, completing the replacement.

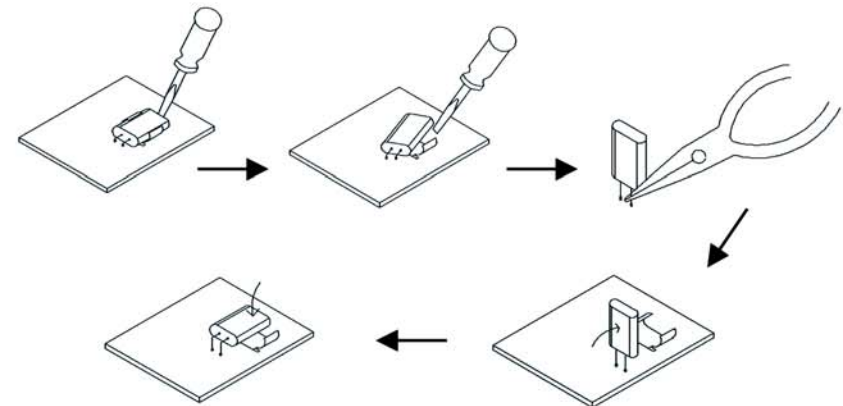

When selecting suitable quartz crystals, pay attention to the markings.

Quartz crystals are usually marked as follows:

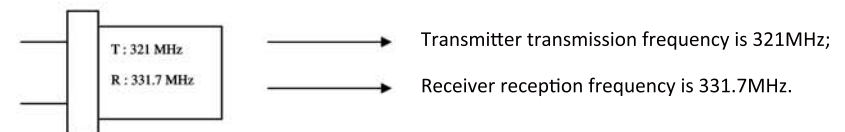

## Common Issues and Solutions

Fault Symptoms	Possible reasons	Solutions
All indicator lights on the transmitter do not light up	<ul style="list-style-type: none"> <li>The transmitter power switch is not turned on (rotary switch is not in the "ON" position);</li> <li>The battery is not installed correctly;</li> <li>The indicator light is damaged.</li> </ul>	<ul style="list-style-type: none"> <li>Check the power switch;</li> <li>Replace or reinstall the battery, Or contact the supplier.</li> </ul>
The transmitter's red indicator light flashes slowly	<ul style="list-style-type: none"> <li>E-card information is not read.</li> </ul>	<ul style="list-style-type: none"> <li>Reinsert the E-card in the correct direction, press the start button for more than 5 seconds, and then reinstall the battery.</li> </ul>
Pressing all action buttons, the red indicator light flashes quickly, and it does not light up when not pressed.	<ul style="list-style-type: none"> <li>One button is stuck;</li> <li>The emergency stop switch is not released;</li> <li>Buttons are operated in the off state;</li> <li>Battery voltage is too low to start.</li> </ul>	<ul style="list-style-type: none"> <li>Check buttons and emergency stop switch;</li> <li>Turn on the power before operating, check if the battery is charged.</li> </ul>
All indicator lights on the receiver do not light up	<ul style="list-style-type: none"> <li>The receiver is not properly powered;</li> <li>The fuse in the receiver is blown.</li> </ul>	<ul style="list-style-type: none"> <li>Check the receiver's power supply and fuse.</li> </ul>
The transmitter and receiver do not communicate.	<ul style="list-style-type: none"> <li>The transmitter and receiver do not match;</li> <li>The transmitter was turned off or lost power during operation;</li> <li>The operating distance is too far;</li> <li>The receiver antenna has poor contact.</li> </ul>	<ul style="list-style-type: none"> <li>Ensure the transmitter and receiver have the same ID and channel group;</li> <li>If the transmitter loses power during operation, restart it to re-establish the connection. Ensure the power is sufficient before turning off and restarting;</li> <li>Ensure the receiver antenna is correctly installed and the receiver is within the permissible range of the transmitter.</li> </ul>
The receiver's power light illuminates after the receiver loses power	<ul style="list-style-type: none"> <li>The receiver's function output terminal is short-circuited;</li> <li>The transmitter power supply is short-circuited.</li> </ul>	<ul style="list-style-type: none"> <li>Check if the function output line is connected to the negative pole or grounded;</li> <li>Check the transmitter's power supply.</li> </ul>
Poor signal transmission or frequent interruptions	<ul style="list-style-type: none"> <li>The signal is strongly interfered with (e.g., high-voltage transmission lines or other wireless signals such as high-power walkie-talkies nearby);</li> <li>The transmitter and receiver are obstructed by objects (e.g., metal plates or walls).</li> </ul>	<ul style="list-style-type: none"> <li>Turn off the machine and restart it. Frequency-hopping products will automatically avoid some interfered channels;</li> <li>Shorten the control distance;</li> <li>Avoid obstacles during operation.</li> </ul>
Individual buttons do not function properly during operation	<ul style="list-style-type: none"> <li>The button function of the transmitter is faulty;</li> <li>The relay controlling the direction corresponding to the non-functioning button on the receiver is damaged, or the relay wiring is poorly connected.</li> </ul>	<ul style="list-style-type: none"> <li>If the transmitter indicator light is normal when operating the transmitter button, the fault is likely in the receiver;</li> <li>If the transmitter indicator light does not light up when operating the transmitter button, the fault is likely in the transmitter;</li> <li>Check the transmitter, and if there is no fault, check the relay or wiring corresponding to the button's control direction.</li> </ul>

## Common Issues and Solutions

Fault Symptoms	Possible reasons	Solutions
The transmitter's red light remains on due to operational errors	<ul style="list-style-type: none"> <li>Usually, the transmitter's flash memory is faulty.</li> </ul>	<ul style="list-style-type: none"> <li>Remove the battery, press the operation buttons multiple times without the battery, and then reinstall the battery. If the problem is not resolved, contact the dealer.</li> </ul>
The receiver suddenly stops working	<ul style="list-style-type: none"> <li>The receiver's flash memory is faulty.</li> </ul>	<ul style="list-style-type: none"> <li>Turn off the receiver power for more than 20 seconds, then turn it back on and observe if the problem is resolved.</li> </ul>

## Packaging and Transportation

- The product is usually packaged in a carton. Avoid storing it in humid and water-soaked environments.
- Packaged products should be stored in a ventilated and dry warehouse with a temperature of -10°C~40°C, relative humidity not exceeding 80%, no strong electromagnetic interference, and no corrosive gases.
- When stacking, the packaging box should be placed according to the indicated direction, and the stacking layers should not exceed six.
- The product usually has outer and inner packaging, meeting the transportation requirements of sea, land, and air.
- During transportation, avoid rain and snow, strong vibrations, or impacts. Do not allow rough handling, stepping, squeezing, or dropping to avoid packaging or product damage.



**Standard Accessories:**  
Transmitter, receiver, battery,  
fuse, protective cover, manual.



**Optional Accessories:**  
USB computer connection copy machine.



## Warranty Terms and Conditions

**Statement:** The use of our products implies the user's agreement to comply with the following terms without any additional conditions.

**Article 1:** Quality Assurance TeleCtrl industrial remote control (hereinafter referred to as "TeleCtrl") guarantees that this product meets the specifications published by the company at the time of shipment. If installed according to the regulations, it can be used normally. However, TeleCtrl cannot guarantee uninterrupted or zero-error operation during use. Users who choose TeleCtrl industrial remote control products must strictly implement their safety facilities to ensure safety and zero injuries.

**Article 2:** Warranty Period and Coverage This product enjoys a one-year warranty from the date of sale. If a quality problem occurs during the warranty period, TeleCtrl is responsible for repairs. If there is no human damage and it does not affect resale, repair or replacement can be negotiated. Any products that need repair must be sent to TeleCtrl's designated service point. Customers can also mail the product to the designated location after paying for one-way freight. TeleCtrl will repair or replace it and send it back. Return freight during the warranty period will be covered by TeleCtrl.

**Article 3:** Exclusions from Warranty Coverage The aforementioned warranty does not cover joysticks, buttons, relays, fuses, batteries, and other consumables. Additionally, issues caused by improper use, unauthorized changes or settings, installation errors, and other problems are not covered. Nor does it include faults caused by force majeure, natural factors, environmental factors, and insufficient maintenance.

**Article 4:** Supplementary Explanation of Responsibilities of TeleCtrl: The above warranty terms do not include other hidden warranty items. The maximum compensation amount provided by the warranty will not exceed the purchase price of the product, which is also the only compensation the user can obtain. TeleCtrl will not assume any other direct, indirect, special, incidental, or consequential losses. All products sold are without installation and commissioning services. Any costs arising from installation, commissioning, or other after-sales issues are borne by the user.

**Article 5:** Reaffirmation Your selection represents your agreement to all the terms listed by TeleCtrl. Both buyers and sellers should strictly abide by the above product usage and warranty regulations. Thank you for your attention and selection of TeleCtrl industrial remote control products!

## Legal Disclaimer and Usage Restrictions

The TeleCtrl Industrial Remote Control is intended for use in industrial environments for equipment control. Users must ensure compliance with local laws and regulations and take necessary safety measures. TeleCtrl is not responsible for any loss or injury resulting from improper use or illegal operation.

## Inspection Certificate

Inspection Items		
1	Transmitter power output test	<input type="checkbox"/> Passed
2	Receiver signal reception sensitivity test	<input type="checkbox"/> Passed
3	Transmitter power-on current test	<input type="checkbox"/> Passed
4	Receiver power-on current test	<input type="checkbox"/> Passed
5	Transmitter button function test	<input type="checkbox"/> Passed
6	Receiver AC contactor simulation on-site test	<input type="checkbox"/> Passed
7	Control distance (greater than 100 meters)	<input type="checkbox"/> Passed
8	Appearance inspection	<input type="checkbox"/> Passed
9	Product accessory inspection	<input type="checkbox"/> Passed
10	Product packaging inspection	<input type="checkbox"/> Passed

## User Feedback and Support

We value your feedback and suggestions. If you have any questions or comments during use, please contact us through the following ways:  
te@telectrl.com